

Model MP-2300ENB
MULTI-PAK BOTTLED AIR CART WITH
LOW PRESSURE ALARM WHISTLE
Manual No. PAK014

Operating Manual



T3 Safety Rentals Ltd

17886 106 Ave, Edmonton, AB T5S 1V4

PH: 780-455-8822

Fax: 780-455-8836

www.t3safety.com

e-mail: sales@t3safety.com

SPECIFICATIONS AND PARTS IDENTIFICATION

Size w/o cylinders:	48H x 25W x 31D
Weight w/o cylinders:	120 lbs.
Frame:	Steel (Powder coated)
Cylinder Straps:	Four (4) adjustable
Whip Assemblies:	5000psi (34.5 bar) rated 4:1 safety factor
Bleeder Valves:	Allows depressurization of hand tight nut
Check Valves:	Allows independent cylinder operation
Low Pressure Whistle:	Pneumatic - set at approximately 500psi (34.5 bar)
Regulator:	0-5500psi (379 bar) inlet 0-125psi (8.6 bar) discharge
Regulator Flow Rate:	80 cfm @ 100psi discharge
Relief Valve:	125psi (8.6 bar) ASME pre set
Air Distribution:	Four (4) quick connect fittings
Intrinsically Safe:	No electronic devices

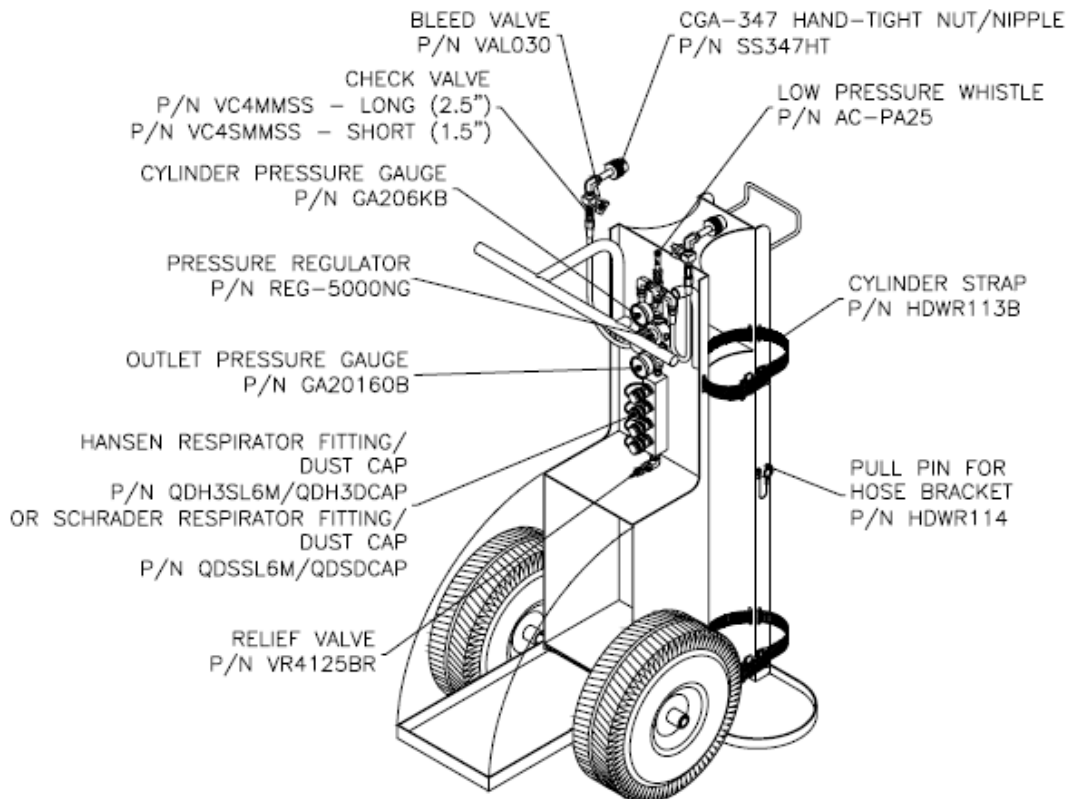

SETUP PROCEDURE

STEP 3)

Open one cylinder. At this time the low pressure warning alarm will sound until it sets itself at approx. 1000psi (69 bar). Check reading on gauge to verify cylinder is full. Close the cylinder.

STEP 4) LOW PRESSURE ALARM TEST

Set the required respirator pressure with the regulator control knob and bleed the pressure at either the relief valve or by partially engaging a male plug into one of the respirator couplings. This depressurizes the manifold and simulates low cylinder pressure. The low pressure warning alarm will sound at approximately 500psi (35bar). Open the other cylinder. Check reading on gauge to verify cylinder is full.

STEP 2)

Install universal CGA-347 hand tight nuts to the cylinder valves and tighten. Insure both bleeder valves are closed by turning fully clockwise.

STEP 1)

Install cylinders on MULTI-PAK™ tray. Secure cylinders by tightening the straps at the buckle and mate the velcro sections to prevent slipping.

STEP 5)

Couple respirators and lengths of hoses to the manifold and readjust pressure regulator if necessary. The system is now operational.

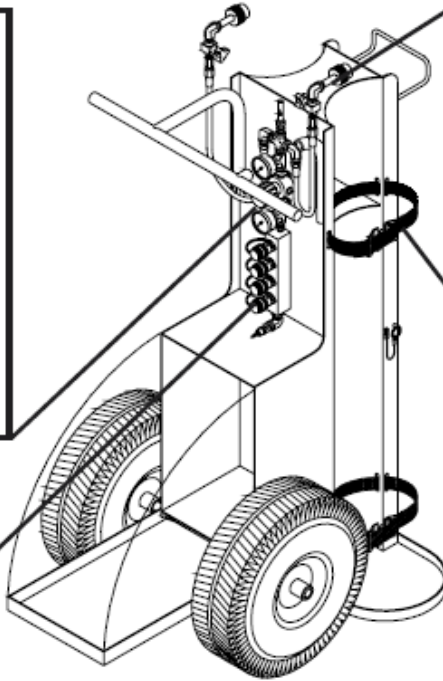

OPERATION

When the cylinder in use has been depleted to approximately 500psi (35 bar), the low pressure warning alarm will sound indicating that the cylinder needs to be replaced.

To change a cylinder while the MULTI-PAK™ is still in use:

- 1) Open the second cylinder and note the gauge pressure to assure that it is full.
- 2) Close the drained cylinder.
- 3) Open the bleeder valve to relieve line pressure. Remove the CGA-347 hand-tight nut.
- 4) Remove the drained cylinder and install a full cylinder in its place. Reinstall the CGA connections. Close bleeder valves. The cylinder is now ready for use when the other cylinder's pressure descends to 500psi.

Note: The system is equipped with check valves that will prevent back flow from the other cylinder in use.

SHUTDOWN

Make sure all personnel have egressed the hazardous area and have disconnected from the breathing air system.

- 1) Close cylinder valves.
- 2) Depressurize manifold pressure by pulling the relief valve ring.
- 3) Close the regulator by turning the control knob counterclockwise.
- 4) Disconnect airline hoses and reinstall dust caps.
- 5) Remove connections from cylinders and reinstall cylinder valve covers (if applicable).

HIGH PRESSURE AIRLINE GENERAL MAINTENANCE & INSPECTION

Monthly

1. Check regulators, gauges, and valves for external leakage.
2. Inspect cylinder valves for proper closure.
3. Check cylinder pigtailed for cleanliness, flexibility, wear, leakage, blisters on hose, thread damage, and O-rings on CGA fittings. Replace damaged items immediately.

Annually

1. Check relief valve's pressure setting.
2. Check regulator function by opening and closing regulator valve knob fully.

Every 4 years

1. Replace all flexible pigtailed - consult factory.